

**ALBERTA GOVERNMENT SERVICES
LAND TITLES OFFICE**

IMAGE OF DOCUMENT REGISTERED AS:

152370533

ORDER NUMBER: 29756475

ADVISORY

This electronic image is a reproduction of the original document registered at the Land Titles Office. Please compare the registration number on this coversheet with that on the attached document to ensure that you have received the correct document. Note that Land Titles Staff are not permitted to interpret the contents of this document.

Please contact the Land Titles Office at (780) 422-7874 if the image of the document is not legible.

RESTRICTIVE COVENANT

In the matter of the Land Titles Act RSA, 2000, Chapter L-4 and amendments thereto; and in the matter of a Restrictive Covenant made pursuant to section 48 thereof:

WHEREAS **GENSTAR TITLECO LIMITED**, a body corporate with an office in the City of Edmonton, in the Province of Alberta (hereinafter sometimes referred to as the "Covenantor" and sometimes as "GENSTAR" as the context of this Restrictive Covenant may require) is the registered owner of those certain lands legally described as set forth in **Schedule "A"** attached hereto (hereinafter referred to as the "Burdened Lands");

AND WHEREAS the Burdened Lands are located in an area within the City of St. Albert, developed and identified by GENSTAR as "**Riverside**" and GENSTAR is the owner of the Lands therein and in the vicinity thereof which it holds for future development, and in particular, but without restricting the generality of the foregoing, GENSTAR is the registered owner of the lands legally described as set forth in **Schedule "B"** hereto (hereinafter referred to as the "Benefited Lands").

AND WHEREAS it is the desire and intention of GENSTAR to impose upon the Burdened Lands beneficial restrictions under a general plan or scheme of improvement for the general benefit of the Benefited Lands and the future owners of the Benefited Lands.

AND WHEREAS for the purposes of aesthetics and consistency, to give a well planned and uniform high standard of appearance, and in order to provide for the Benefited Lands and the Burdened Lands to be developed as a residential subdivision and to maintain the aesthetics of the Burdened Lands and the Benefited Lands it is essential that a specific style of Fence be built and that, if the value of the Benefited lands and the Burdened Lands is not to be depreciated, Purchasers be prevented from building any other style, type or design of Fence.

NOW THEREFORE the Covenantor hereby for itself, its transferees and assignees and successors in title, declare, covenant and agree as follows:

1. In this agreement, including this paragraph, unless the context otherwise requires:
 - a) "Horizontal Wood Screen with Steel Panels" means the Horizontal Wood Screen Fence with Steel Panels at 10.36m spacing constructed or to be constructed substantially in accordance with the specifications attached hereto as **Schedule C** and to be erected on the Burdened Lands.
 - b) "Existing Fence Lines" means those portions of the side or rear property lines of the Burdened Lands identified as being Existing Fencing on the sketch attached thereto as **Schedule G**.
 - c) "Existing Fencing" means the Existing Fencing, (being Step Down Wood Screen, Wood Screen or Horizontal Wood Screen with Steel Panels as the case may be) constructed (or to be constructed) by Genstar or others upon the property lines of the Burdened Lands as identified on the sketch attached hereto as **Schedule G**.
 - d) "Future Fence Lines" means those portions of the side or rear property lines of the Burdened Lands identified as being Future Fencing on the sketch attached hereto as **Schedule G**.
 - e) "Future Fencing" means the Future Fencing, (being Wood Screen, Vertical Wood Screen or Step Down Wood Screen as the case may be) to be constructed upon the property lines of the Burdened Lands as identified on the sketch attached hereto as **Schedule G**.
 - f) "Purchaser" or "Purchasers" means any person or body corporate who acquires the Burdened Lands or any lot within the Benefited Lands from GENSTAR and any successor in title to such person.
 - g) "Step Down Wood Screen" means the Horizontal Step Down Wood Screen Fence to be constructed in accordance with the specifications attached hereto as **Schedule E**.

- h) "Wood Screen" means the Horizontal Wood Screen Fence to be constructed substantially in accordance with the specifications attached hereto as **Schedule "D"** and to be erected upon the Burdened Lands.
- i) "Vertical Wood Screen" means the Vertical Wood Screen Fence to be constructed substantially in accordance with the specifications attached hereto as **Schedule "F"** and to be erected upon the Burdened Lands.
2. The Burdened Lands shall not be transferred, conveyed, hypothecated or encumbered, leased, rented, used, occupied or improved excepting subject on to the following limitations, restrictions, conditions and covenants, all of which are declared and agreed to be in furtherance of a plan for the improvement and sale of the Burdened Lands and Benefited Lands and are established and agreed upon for the purposes of enhancing and protecting the value, desirability and attractiveness of both the Burdened Lands and the Benefited Lands and every part thereof. All of the limitations, restrictions, conditions and covenants shall run with the Burdened Lands and shall be binding on all parties having or acquiring any right, title or interest in the Burdened Lands or any part thereof, and to the further intent that the benefit thereof may be annexed to and run with the Benefited Lands and any part thereof.
 3. A Purchaser shall not construct future fencing on the Burdened Lands unless it is of the type designated for the lands as shown on **Schedule G** and is constructed substantially in accordance with the specifications attached hereto as **Schedule "C", "D", "E" or "F"**, as the case may require, and provided further that such fencing is constructed in accordance with regulations governing the construction of fences established from time to time by the City of St. Albert.
 4. No Purchaser shall by act or omission cause or allow the Future Fencing, once constructed, to be disturbed, damaged, removed, interfered with, changed or tampered with in any manner whatsoever, nor shall any Purchaser allow the Future Fencing to fall into a state of disrepair. The Purchaser will be responsible for all costs for building, maintaining, repairing or replacing the Future Fencing.
 5. No Purchaser shall by act or omission cause or allow the Existing Fencing, once constructed, to be disturbed, damaged, removed, interfered with, changed or tampered with any manner whatsoever, nor shall any Purchaser allow the Existing Fencing to fall into a state of disrepair. The Purchaser will be responsible for all costs for maintaining, repairing or replacing the Existing Fencing in the same style, type, design and location in which it was originally constructed.
 6. The restrictions described in this restrictive covenant shall bind the Burdened Lands from the date hereof until January 1, 2035.
 7. The restrictive covenants set out herein are enforceable jointly and severally by GENSTAR and the registered owner or registered owners from time to time of the Benefited Lands and any waiver by any registered owner of any portion of the Benefited Lands of the strict performance of the covenants set out herein shall not of itself constitute a waiver or abrogate the covenants set out herein.
 8. The rights, privileges, covenants and obligations herein contained shall extend to, shall be binding upon and shall enure to the benefit of the parties hereto and every purchaser or transferee or subsequent registered owner of the Burdened Lands or the Benefited Lands as the case may be and their respective successors and assigns.
 9. Any provision of this agreement made void or rendered invalid by any law in force in the Province of Alberta or adjudged not to be covenant running with the Burdened Lands shall not invalidate or render unenforceable the remaining provisions of this agreement.
 10. No action shall lie as against the Covenantor for damages for the breach of any one or more of the covenants contained in this agreement unless such party remains the registered owner of the Burdened Lands and is proven by a court of competent jurisdiction to be in breach of this agreement. This covenant shall constitute an absolute defense to any such action and may be pleaded as such.

11. GENSTAR shall be entitled to enforce the provisions of this Restrictive Covenant in its complete and absolute discretion and may, without reasons, determine not to enforce any or all of the covenants herein contained without liability whatsoever. In particular, without limiting the generality of the foregoing, GENSTAR may waive, alter or modify these restrictions in respect to any portion of the Burdened Lands without notice to the owner of any other portion of the Benefited Lands as long as GENSTAR retains ownership of any portion of the Benefited Lands and provided that such waiver, alteration or modification does not reasonably offend the spirit and intent of this Restrictive Covenant.

IN WITNESS WHEREOF **GENSTAR TITLECO LIMITED**, has hereunto affixed its corporate seal, duly attested by it properly authorized officers, this 22nd day of January, 2015.

GENSTAR TITLECO LIMITED

Per 

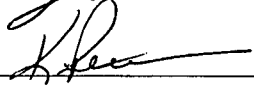
Per 

SCHEDULE "A"

TO THE RESTRICTIVE COVENANT

Burdened Lands

PLAN 152 5301
BLOCK 1
LOTS 53 TO 72 INCLUSIVE
EXCEPTING THEREOUT ALL MINES AND MINERALS

PLAN 152 5301
BLOCK 2
LOTS 26 TO 35 INCLUSIVE
EXCEPTING THEREOUT ALL MINES AND MINERALS

SCHEDULE "B"

TO THE RESTRICTIVE COVENANT

Benefitted Lands

PLAN 152 5301
BLOCK 1
LOTS 53 TO 72 INCLUSIVE
EXCEPTING THEREOUT ALL MINES AND MINERALS

PLAN 152 5301
BLOCK 2
LOTS 26 TO 35 INCLUSIVE
EXCEPTING THEREOUT ALL MINES AND MINERALS

NOTE:
 -ALL CORTEN PANELS TO BE INSTALLED WHERE A CHANGE OF DIRECTION OF THE PROPERTY LINE OCCURS.
 -ALL CORTEN PANELS TO BE EQUALLY SPACED WHEN 10.36m O.C. IS NOT POSSIBLE.
 -ALL CORTEN PANELS TO BE POWDER COATED STEEL WITH COLOR: A606 TYPE 4 OR A588 (RUSTY OR CORTEN FINISH)
 -ALL HARDWARE TO BE POWDER COATED WITH ST-ALBERT RED.

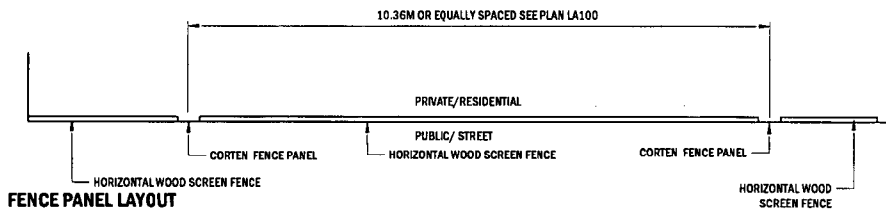

FENCE PANEL LAYOUT

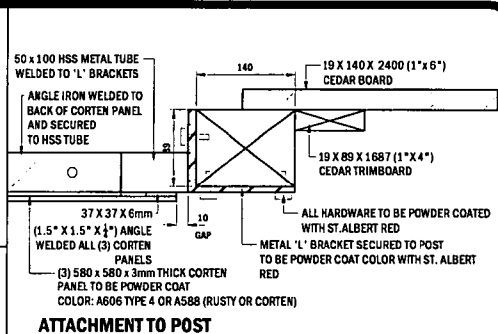

ATTACHMENT TO POST

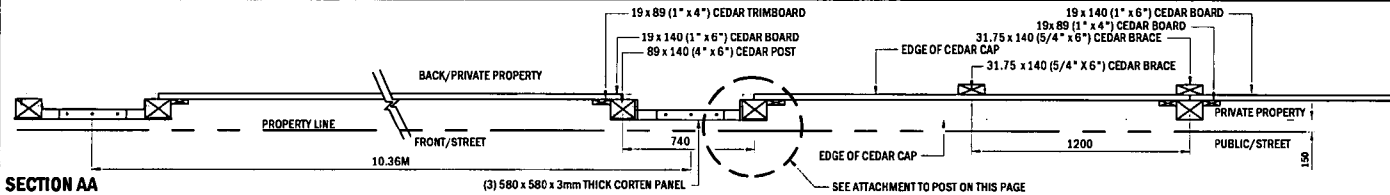

SECTION AA

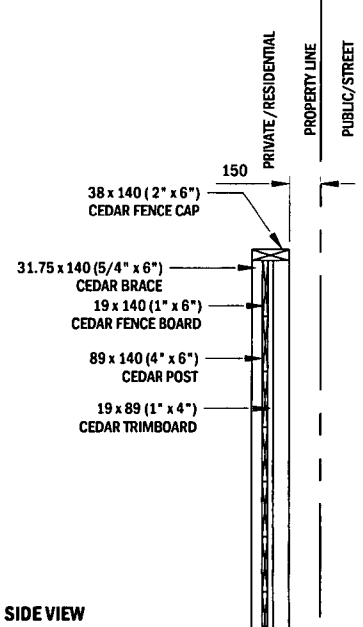

SIDE VIEW

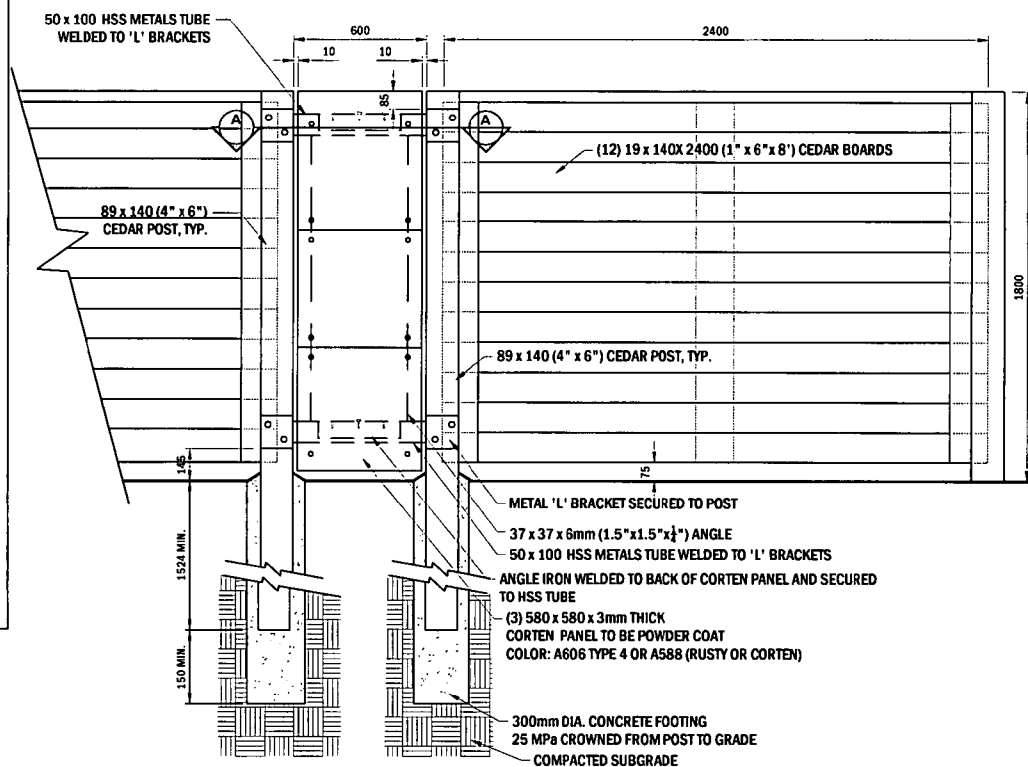

ELEVATION VIEW

DETAIL

- WOOD SCREEN FENCE NOTES:**
1. WORK SHALL BE DONE IN ACCORDANCE WITH THE FOLLOWING STANDARDS:
 - CONCRETE - CSA CAN3-A23.1-M77
 2. MATERIAL SHALL MEET THE FOLLOWING SPECIFICATIONS:
 - CEMENT - TYPE 50, SULPHATE RESISTANT CSA CAN3-A5-M77, PORTLAND CEMENT
 - CONCRETE - 28 DAY STRENGTH $f_c = 25\text{MPa}$
 - 28mm MAXIMUM AGGREGATE
 - 50 - 80mm SLUMP
 - MAXIMUM W/C RATIO = 0.5
 - 5 - 7% AIR ENTRAINMENT
 3. CONTRACTOR SHALL INVESTIGATE THE EXCAVATED SUB SOIL MATERIAL FOR "SOFT SPOTS" (FOR INSTANCE FILL AREAS OF PREVIOUSLY INSTALLED TRENCHES ETC.) AND NOTIFY THE LANDSCAPE ARCHITECT IF SOFT SPOTS ARE FOUND. SOFT SPOTS SHALL BE RECOMPACTED TO 100% STD-PROCTOR DENSITY
 4. MAXIMUM MISALIGNMENT OF PILES SHALL NOT EXCEED 50mm.
 5. ALL FENCE POSTS ARE TO BE CEDAR.
 6. ALL FENCE WOOD (POST, TRIMBOARD, BOARD, CAP, BRACE) TO BE PRE-STAINED OR MECHANICAL ROLLED WITH TWO COATS OF COLOR # 214 HICKORY (FROM SIKKENS) BOTH SIDES PRIOR TO INSTALLATION, TO FOLLOW MANUFACTURERS SPECIFICATIONS.
 7. ALL FASTENINGS TO BE GALVANIZED MINIMUM FOUR NAILS PER BOARD TO POST, THREE NAILS PER BRACE TO BOARD.
 8. FENCE TO BE SET 150mm INSIDE PRIVATE PROPERTY.
 9. FENCE TO BE MAINTAINED FOR TWO YEARS PRIOR TO F.A.C.
 10. ALL DIMENSIONS ARE IN MILLIMETERS OR OTHERWISE NOTED.

HORIZONTAL WOOD SCREEN FENCE W/CORTEN PANEL @ 10.36m SPACING

CONSTRUCTION SPECIFICATIONS

Genstar Development Company
 RIVERSIDE STAGE 1
 City of St. Albert



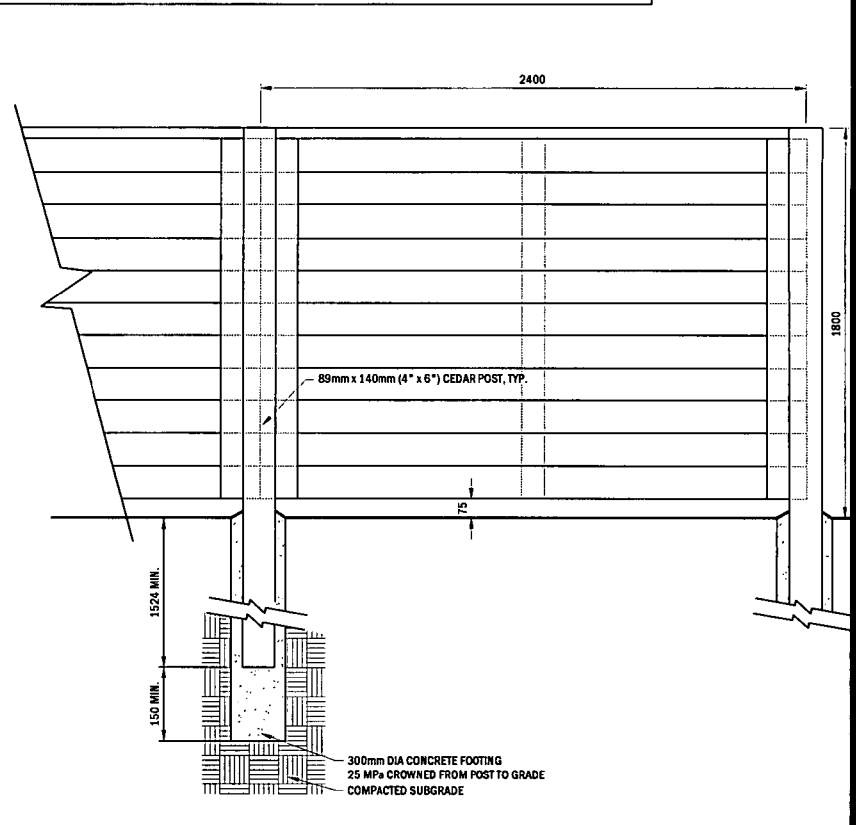
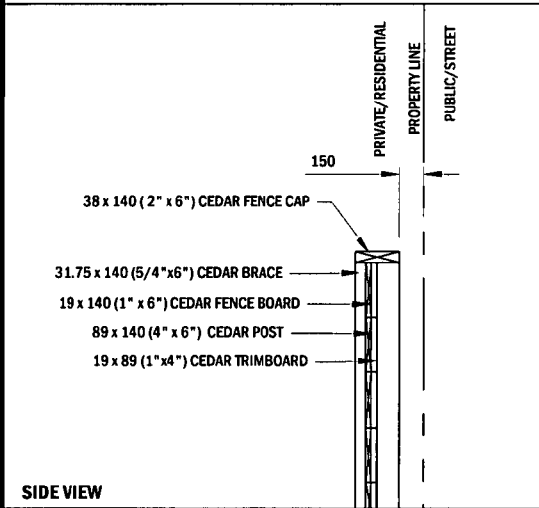
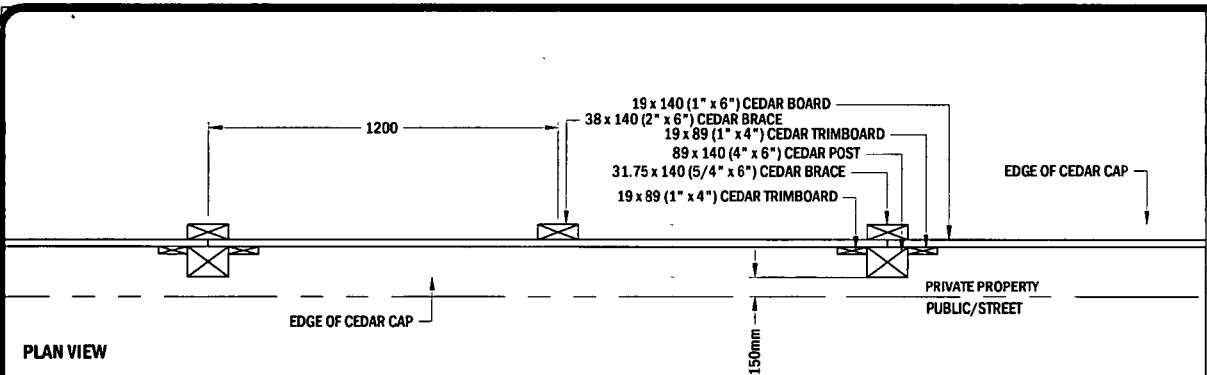

ELEVATION VIEW

DETAIL

WOOD SCREEN FENCE NOTES:

1. WORK SHALL BE DONE IN ACCORDANCE WITH THE FOLLOWING STANDARDS:
 - CONCRETE - CSA CAN3-A23.1-M77
2. MATERIAL SHALL MEET THE FOLLOWING SPECIFICATIONS:
 - CEMENT - TYPE 50, SULPHATE RESISTANT CSA CAN3-A5-M77, PORTLAND CEMENT
 - CONCRETE - 28 DAY STRENGTH $f_c = 25\text{MPa}$
 - 28mm MAXIMUM AGGREGATE
 - 50 - 80mm SLUMP
 - MAXIMUM W/C RATIO = 0.5
 - 5 - 7% AIR ENTRAINMENT
3. MAXIMUM MISALIGNMENT OF PILES SHALL NOT EXCEED 50mm.
4. ALL FENCE POSTS ARE TO BE CEDAR.
5. ALL FENCE WOOD (POST, TRIMBOARD, BOARD, CAP, BRACE) TO BE PRE-STAINED OR MECHANICAL ROLLED WITH TWO COATS OF COLOR #214 HICKORY (FROM SIKKENS) BOTH SIDES PRIOR TO INSTALLATION, TO FOLLOW MANUFACTURERS SPECIFICATIONS.
6. ALL FASTENINGS TO BE GALVANIZED MINIMUM FOUR NAILS PER BOARD TO POST, THREE NAILS PER BRACE TO BOARD.
7. FENCE TO BE SET 150mm INSIDE PRIVATE PROPERTY.
8. FENCE TO BE MAINTAINED FOR TWO YEARS PRIOR TO F.A.C.
9. ALL DIMENSIONS IN MILLIMETERS OR OTHERWISE NOTED.

HORIZONTAL WOOD SCREEN FENCE CONSTRUCTION SPECIFICATIONS

Genstar Development Company
 RIVERSIDE STAGE 1
 City of St. Albert



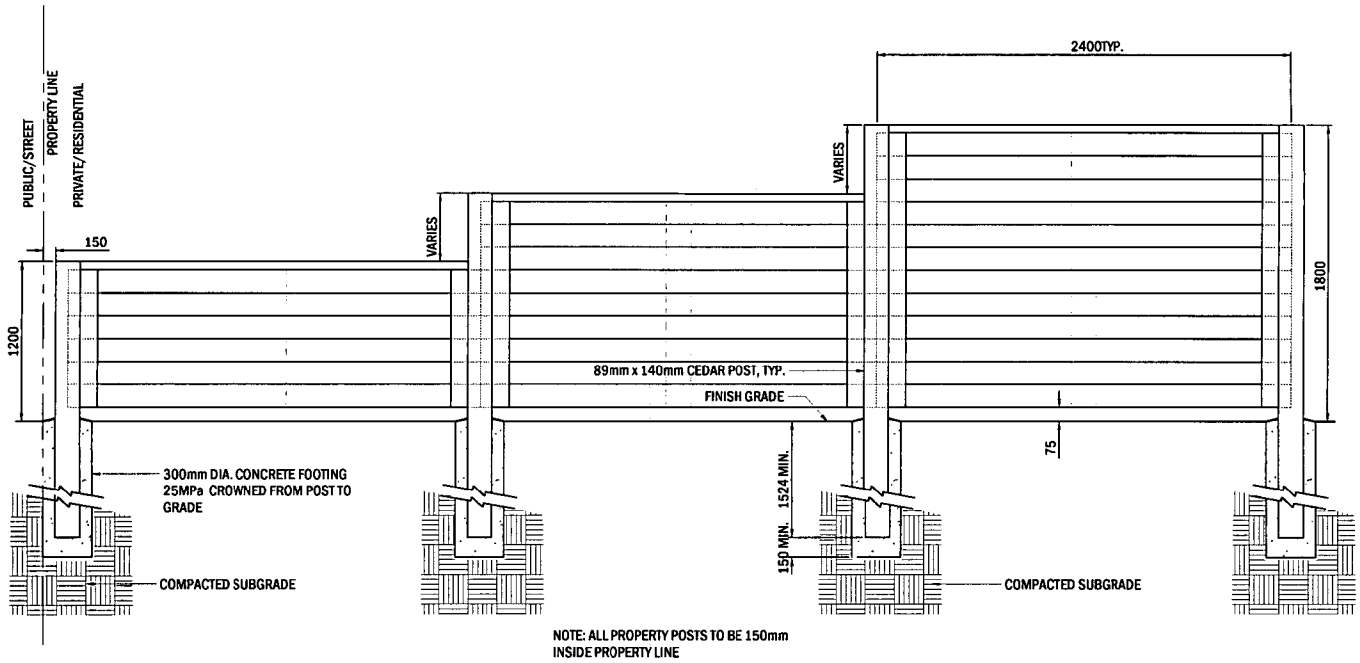

ELEVATION VIEW

DETAIL

WOOD SCREEN FENCE NOTES:

1. WORK SHALL BE DONE IN ACCORDANCE WITH THE FOLLOWING STANDARDS:
 - CONCRETE - CSA CAN3-A23.1-M77
2. MATERIAL SHALL MEET THE FOLLOWING SPECIFICATIONS:
 - CEMENT - TYPE 50, SULPHATE RESISTANT CSA CAN3-A5-M77, PORTLAND CEMENT
 - CONCRETE - 28 DAY STRENGTH $f_c=25MPa$
 - 28mm MAXIMUM AGGREGATE
 - 50 - 80mm SLUMP
 - MAXIMUM W/C RATIO = 0.5
 - 5 - 7% AIR ENTRAINMENT
3. MAXIMUM MISALIGNMENT OF PILES SHALL NOT EXCEED 50mm.
4. ALL FENCE POSTS ARE TO BE CEDAR.
5. ALL FENCE WOOD (POST, TRIMBOARD, BOARD, CAP, BRACE) TO BE PRE-STAINED OR MECHANICAL ROLLED WITH TWO COATS OF COLOR # 214 HICKORY (FROM SIKKENS) BOTH SIDES PRIOR TO INSTALLATION, TO FOLLOW MANUFACTURERS SPECIFICATIONS.
6. ALL FASTENINGS TO BE GALVANIZED MINIMUM FOUR NAILS PER BOARD TO POST, THREE NAILS PER BRACE TO BOARD.
7. FENCE TO BE SET 150mm INSIDE PRIVATE PROPERTY.
8. FENCE TO BE MAINTAINED FOR TWO YEARS PRIOR TO F.A.C.
9. ALL DIMENSIONS IN MILLIMETERS OR OTHERWISE NOTED.

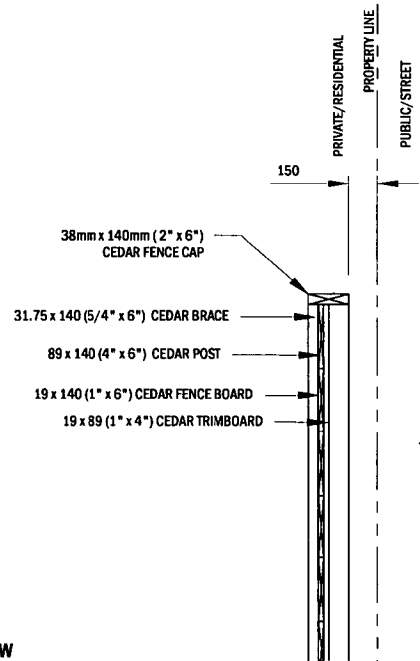

SIDE VIEW

HORIZONTAL STEPDOWN WOOD SCREEN FENCE CONSTRUCTION SPECIFICATIONS

Genstar Development Company
 RIVERSIDE STAGE 1
 City of St. Albert

Schedule E



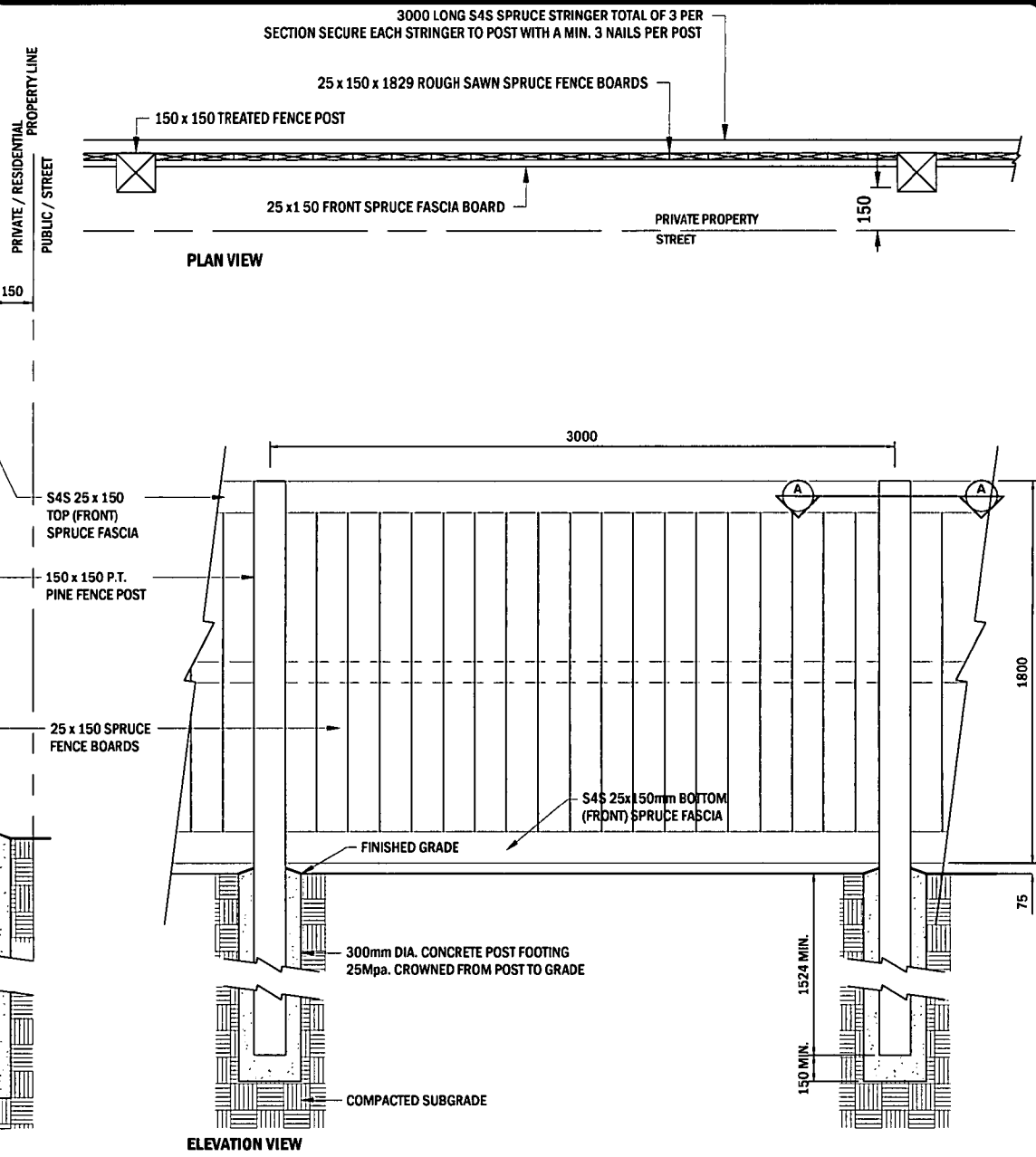

D-TAIL

WOOD SCREEN FENCE NOTES:

1. WORK SHALL BE DONE IN ACCORDANCE WITH THE FOLLOWING STANDARDS:
 - CONCRETE - CSA CAN3-A23.1-M77
2. MATERIAL SHALL MEET THE FOLLOWING SPECIFICATIONS:
 - CEMENT - TYPE 50, SULPHATE RESISTANT CSA CAN3-A5-M77, PORTLAND CEMENT
 - CONCRETE - 28 DAY STRENGTH $f_c = 25\text{MPa}$
 - 28mm MAXIMUM AGGREGATE
 - 50 - 80mm SLUMP
 - MAXIMUM W/C RATIO - 0.5
 - 5 - 7% AIR ENTRAINMENT
3. MAXIMUM MISALIGNMENT OF PILES SHALL NOT EXCEED 50mm.
4. ALL FENCE POSTS ARE TO BE CEDAR OR SPRUCE.
5. ALL FENCE WOOD (POST, BOARD, STRINGER, FASCIA) TO BE PRE-STAINED OR MECHANICAL ROLLED WITH TWO COATS OF COLOR #214 HICKORY (FROM SIKKENS) BOTH SIDES PRIOR TO INSTALLATION, TO FOLLOW MANUFACTURERS SPECIFICATIONS.
6. ALL FASTENINGS TO BE GALVANIZED MINIMUM FOUR NAILS PER BOARD TO POST, THREE NAILS PER BRACE TO BOARD.
7. FENCE TO BE SET 150mm INSIDE PRIVATE PROPERTY.
8. FENCE TO BE MAINTAINED FOR TWO YEARS PRIOR TO F.A.C.
9. ALL DIMENSIONS ARE IN MILLIMETERS OR OTHERWISE NOTED.

VERTICAL WOOD SCREEN FENCE CONSTRUCTION SPECIFICATIONS

Genstar Development Company
 RIVERSIDE STAGE 1
 City of St. Albert



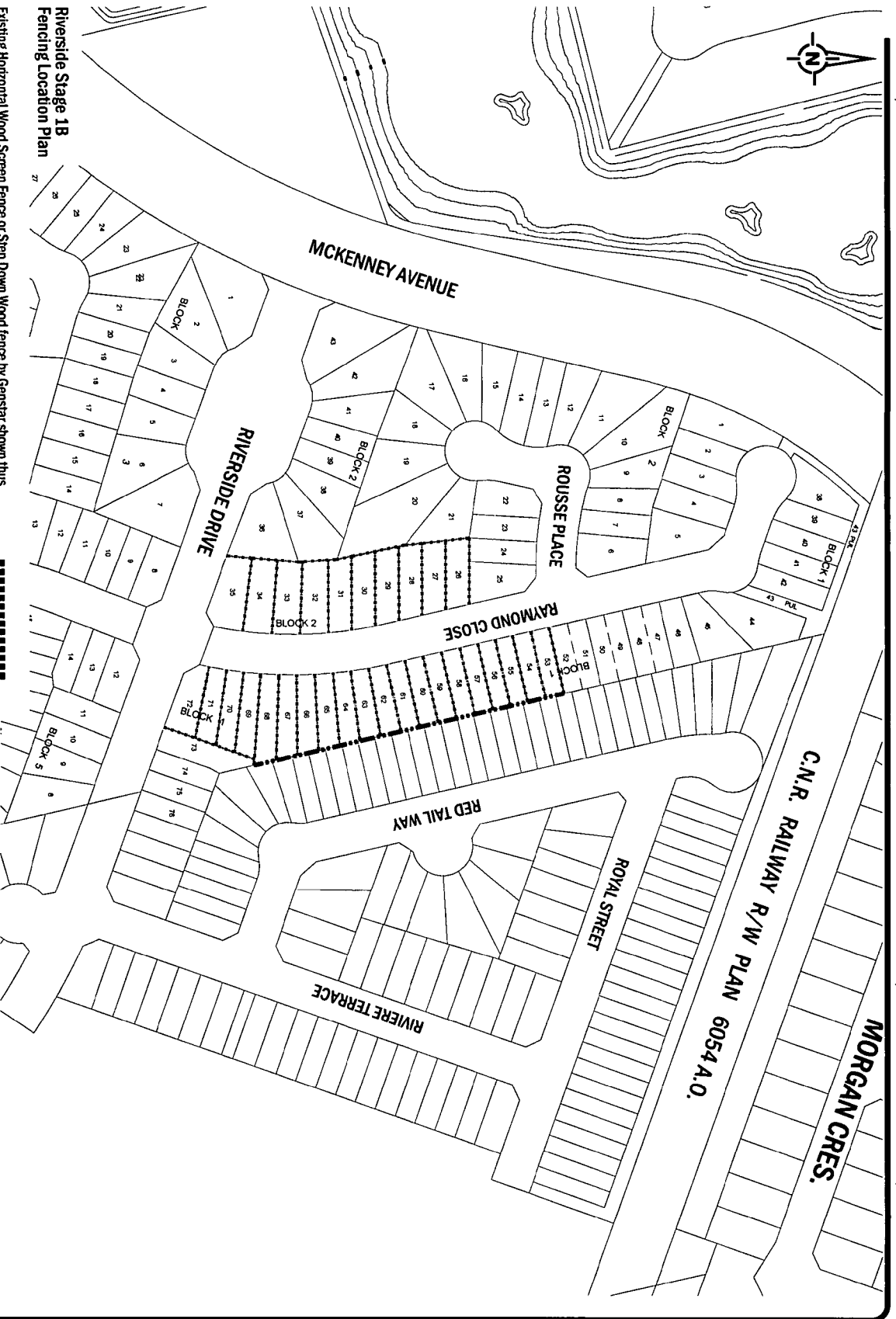

**Riverside Stage 1B
Fencing Location Plan**

- Existing Horizontal Wood Screen Fence or Step Down Wood fence by Genstar shown thus
- Existing Wood Screen Fence by Reid Development shown thus
- Future Horizontal, Vertical or Step Down Wood Screen Fence by Home Owner shown thus
- Future Horizontal Stepdown Wood Fence by Homeowner shown thus

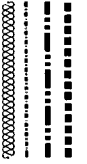



152370533

152370533 REGISTERED 2015 11 26
RESC - RESTRICTIVE COVENANT
DOC 6 OF 7 DRR#: C0FD734 ADR/CRJONES